

SWING ARM SPACERS

Some CBX's prior to frame serial number 2006026 use 0.25mm thick spacers between the swing arm bushings and dust seals (Fig. 1). The spacers are used to maintain a standard swing arm collar measurement of 0.70mm to 1.10mm longer than the pivot width.

You can determine if a CBX swing arm requires spacers by following these instructions:

1. Measure the swing arm pivot width with bushings only installed (Fig. 2).
2. Measure the swing arm collar length (Fig. 3, Page 2).
3. Subtract the pivot width from the collar length. The collar length should measure 0.70 to 1.10mm longer than the pivot width. If so, spacers are not required.

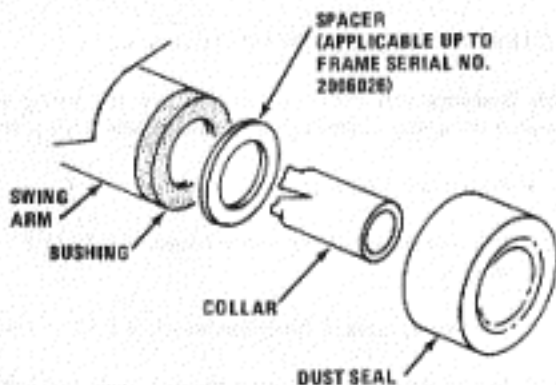

FIG. 1

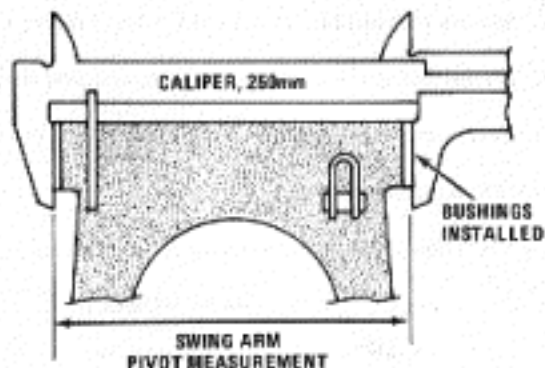

FIG. 2

ROUTING:

COPY 1
COPY 2

- | | | |
|--|--------------------------------------|--------------------------------------|
| <input type="checkbox"/> GENERAL MANAGER | <input type="checkbox"/> SALES DEPT. | <input type="checkbox"/> OFFICE FILE |
| <input type="checkbox"/> SERVICE MANAGER | <input type="checkbox"/> MECHANICS | <input type="checkbox"/> SHOP MANUAL |

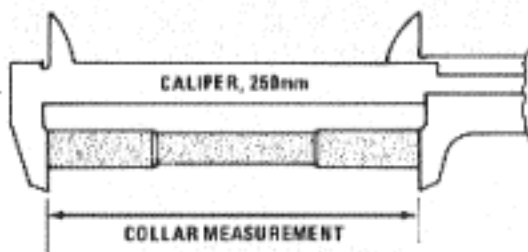

FIG. 3

(ALTERNATE MEASURING METHOD):

With bushings and collar installed, place the swing arm on a surface plate. Measure the distance the collar extends past the swing arm with a depth caliper or a feeler gauge.

4. If spacers are required:

- * Use *one* spacer if the collar length is *1.11 to 1.35mm longer*. Install only on the right side.
- * Use *two* spacers if the collar length is *1.36 to 1.60mm longer*. Install one on each side.
- * Install the spacers between the dust seals and bushings.
- * If more than two spacers are necessary, inspect the swing arm bushings for wear or damage.

NOTES:

- A. Spacers should only be removed when a swing arm is replaced (See Parts Information).
- B. Do not add spacers unless you determine that they are required.
- C. CBX's after frame serial number 2006026 do not require swing arm spacers.

PARTS INFORMATION:

Use the following parts information to order swing arm spacers.

H/C	PART NUMBER	DESCRIPTION
43389	44809-402-000	Spacer (0.25mm thick)

Replacement swing arms from American Honda's Parts Department do not require spacers.

AMERICAN HONDA MOTOR CO., INC.
SERVICE COMMUNICATIONS DEPARTMENT